

JET 17" Drill Press

Description	Drill Press – Model JDP-17MF
Size / Horse power	17" / 3/4 HP / 200-3630 RPM
Power source	115 volt through power cord
Uses	Drilling/Boring holes into various material (metal, wood, plexiglas, plastic)

Safety Precautions

Hazards
Flying debris (potential eye damage)
Electrical shock
Abrasions
Entanglement of hair or clothing
Training
Shop Safety Fundamentals
Site Specific Training
Protective Equipment
Safety glasses
Hearing protection
Avoid loose fitting clothing
Tie back long hair



Operation

Startup

1. Put on PPE listed above
2. Ensure work area is clean and free of obstacles
3. Make necessary adjustments for safe operation
4. Inspect the tool for damage or obstructions to operation
5. Place material so that it is resting against the left side of the column to prevent material from spinning or securely fasten material to the table
6. Make sure the drill chuck is tightened down on the drill bit and the chuck key has been removed
7. Turn on the drill press using the START button located on the front of the tool
8. Begin work
9. Slowly feed drill bit towards material, avoid feeding material too quickly or too slowly
10. Keep hands clear of drill bits

Depth Stop Adjustment

1. Mark a reference to the depth the bit will drill into the material
2. With the drill bit in the chuck, lower down feed handle to advance bit to your mark
3. Advance the lock nuts (A) on the depth stop rod until they are snug to the seat (B)
4. The drill bit will now only advance to this depth
5. To release, advance the nuts counter-clockwise to the top of the depth stop



Changing Spindle Speeds – Performed By Authorized Personnel ONLY

1. Use the pulley/belt arrangement chart found on the inside of the pulley cover or page 15 in the manual when changing speeds
2. Unplug the drill press from the power source
3. Loosen the two bar knobs (C) found on each side of the head assembly
4. Rotate the tension adjuster (D) clockwise to bring the motor base as close to the head as possible
5. Change the location of belts per pulley/belt arrangement chart for desired speed
6. Rotate the tension adjuster (D) counterclockwise to tension the belts, belts are properly tensioned when finger and thumb pressure midway between the two pulley causes approximately 1/2" deflection
7. Tighten the two bar knobs (C)

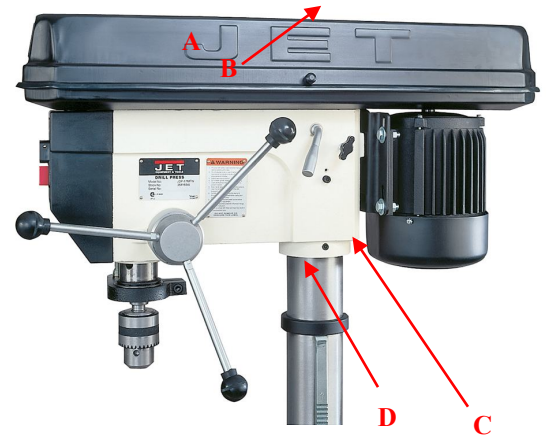
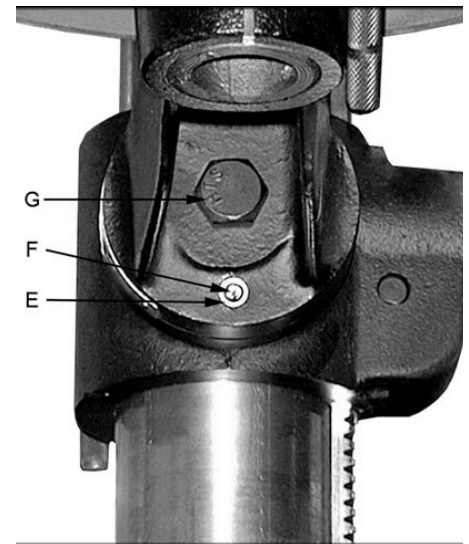

Table Tilt Adjustment

1. Turn nut (E) clockwise to pull out the alignment pin (F)
2. Loosen hex cap bolt (G), and tilt the table to the desired angle
3. Tighten the hex cap bolt (G)
4. The alignment pin only works at 90° and must be reinserted when the table is returned to 90°



Shutdown

1. Turn off the drill press using the STOP button located on front of the tool
2. Allow the chuck to come to a complete stop on its own
3. Remove work piece for tabletop

Note: To safeguard the machine from unauthorized operation and to avoid accidentally starting during maintenance, the use of a padlock is highly recommended

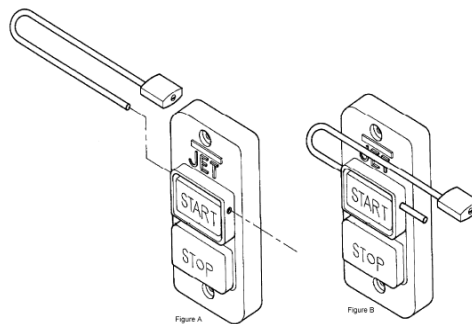

Maintenance

Storage	
Care	<ul style="list-style-type: none"> • Clean off drill press after you are done using • Periodically lubricate the gear and the rack, the table elevation mechanism, the grooves in the spindle and the teeth of the quill with a #2 tube grease
Accessories	